

[54] CAMOUFLAGED AND DECEPTIVE DISTORTED VEHICLE AND METHOD OF ASSEMBLING SUCH VEHICLES

[76] Inventor: Carlisle K. Ferris, 50 Moraine Rd., Morris Plains, N.J. 07950

[21] Appl. No.: 901,799

[22] Filed: May 1, 1978

[51] Int. Cl.² B64D 7/00

[52] U.S. Cl. 244/1 R; 427/280; 428/919

[58] Field of Search 89/36 R, 36 Z; 114/15; 224/1 R; 427/262, 267, 274, 280; 428/195, 919

[56] References Cited

U.S. PATENT DOCUMENTS

715,013	12/1902	Brush et al.	114/15
1,296,753	3/1919	Brush	428/919

Primary Examiner—Stephen C. Bentley
Attorney, Agent, or Firm—Shlesinger, Arkwright, Garvey & Dinsmore

[57] ABSTRACT

A camouflaged and deceptive distorted vehicle comprising a top and bottom surface, the surfaces having pairs of coordinate sections including a fore and aft coordinate sections pair and a second left and right coordinate sections pair, at least one of the two pairs of coordinate sections of the top surface being colored, and the color on at least one of the two pairs of coordinate sections of the top surface graduating from dark to light beginning dark on one section and ending light on the other section, and including the method of assembling such vehicles.

70 Claims, 17 Drawing Figures

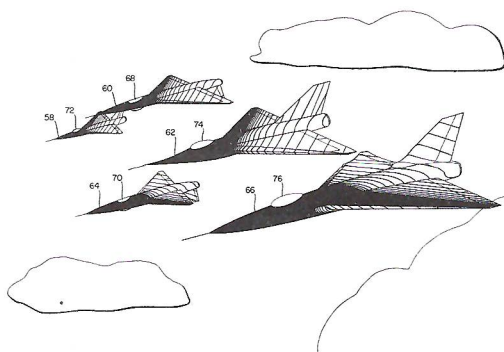

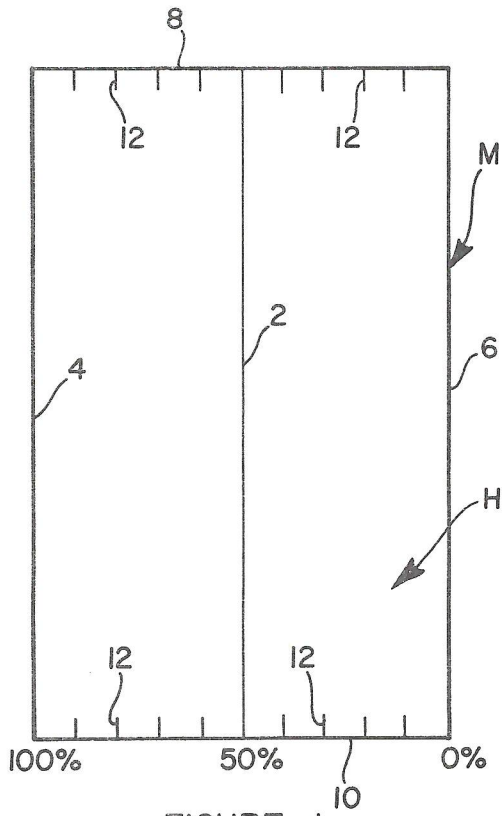

FIGURE 1

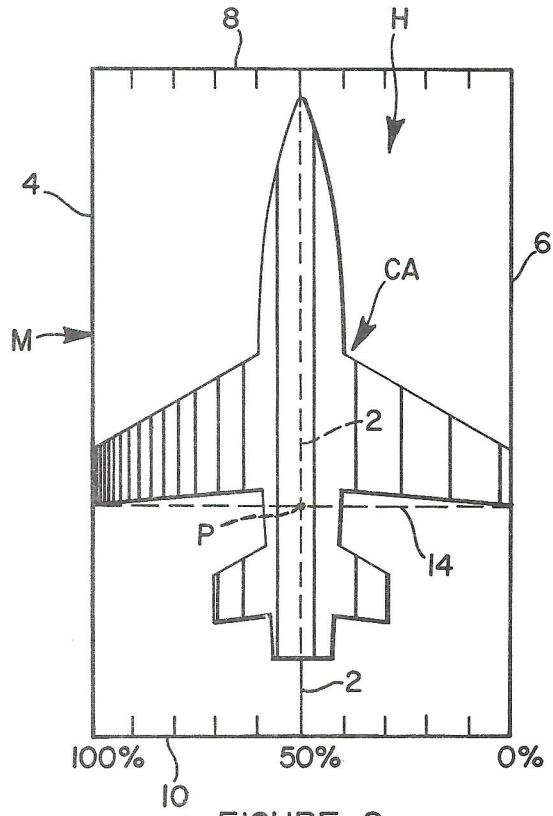

FIGURE 2

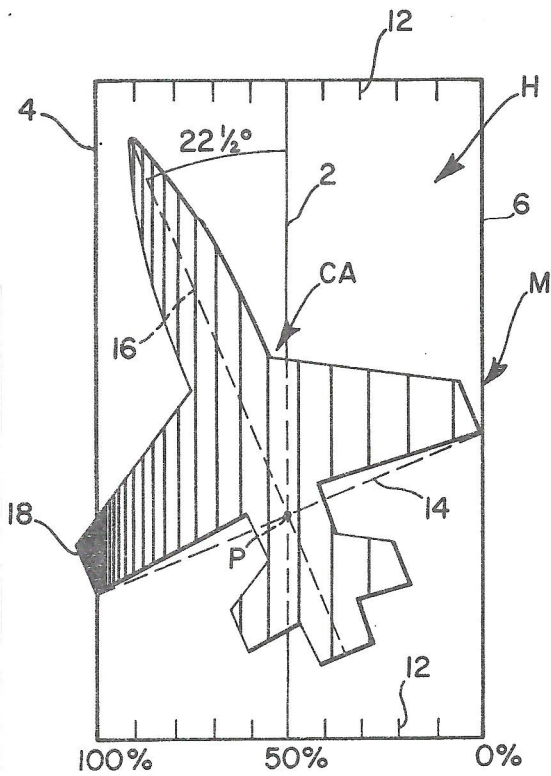

FIGURE 3

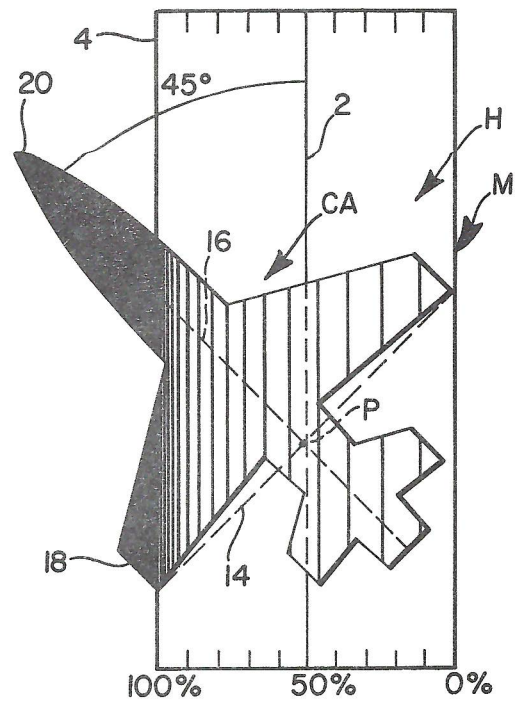

FIGURE 4

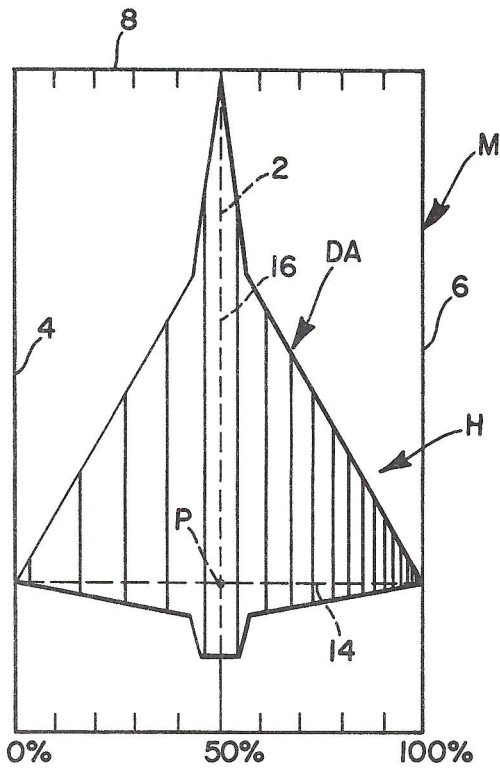

FIGURE 5

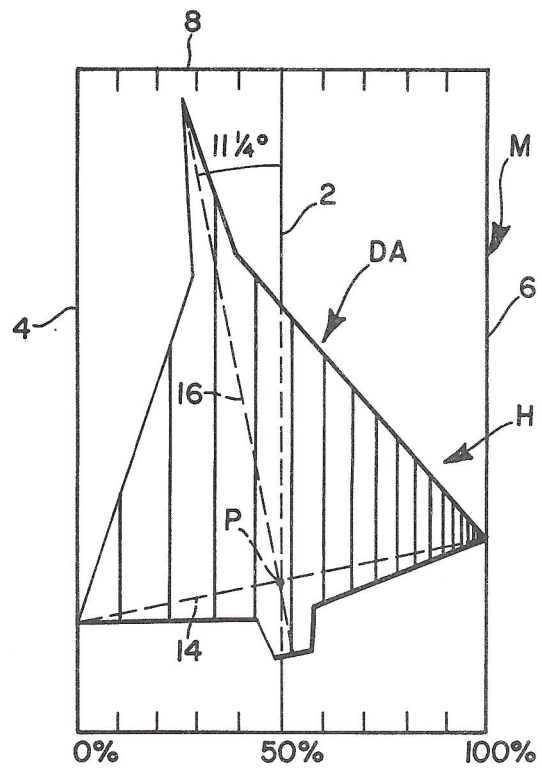

FIGURE 6

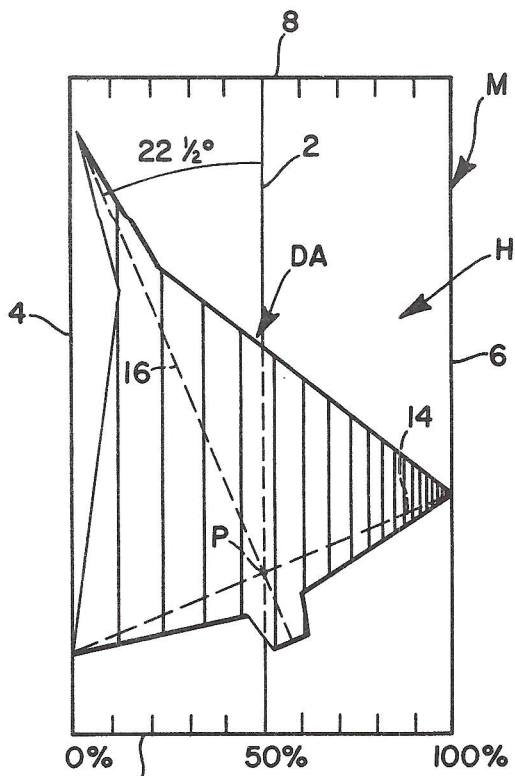

FIGURE 7

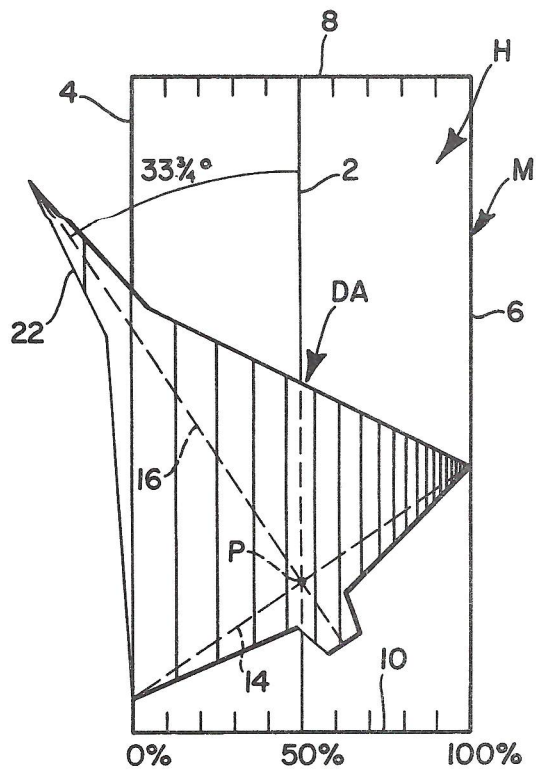

FIGURE 8

FIGURE 9

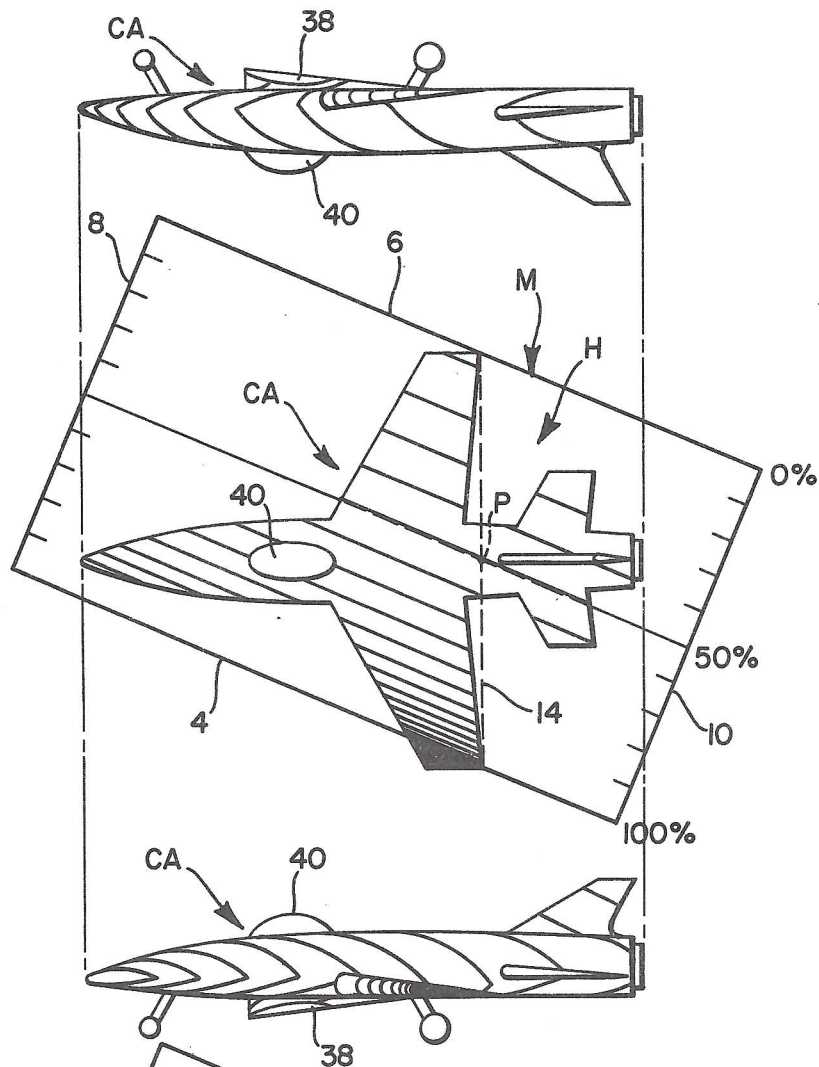
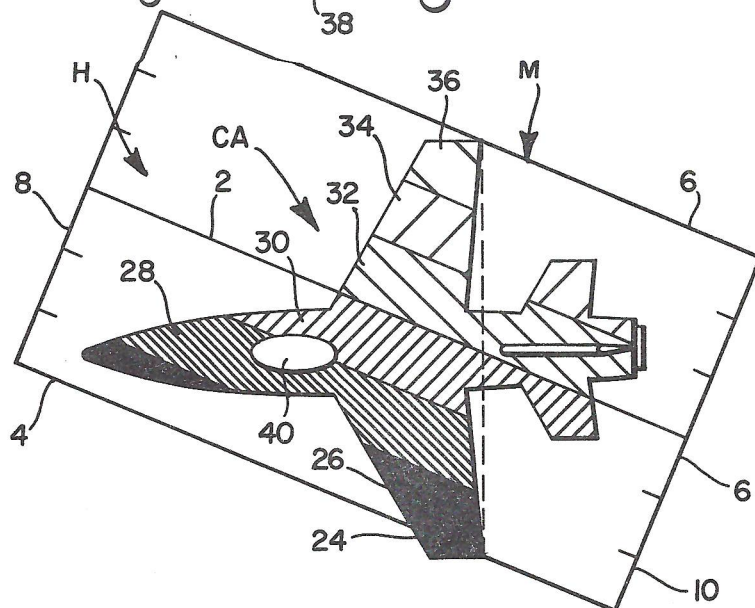

FIGURE 10



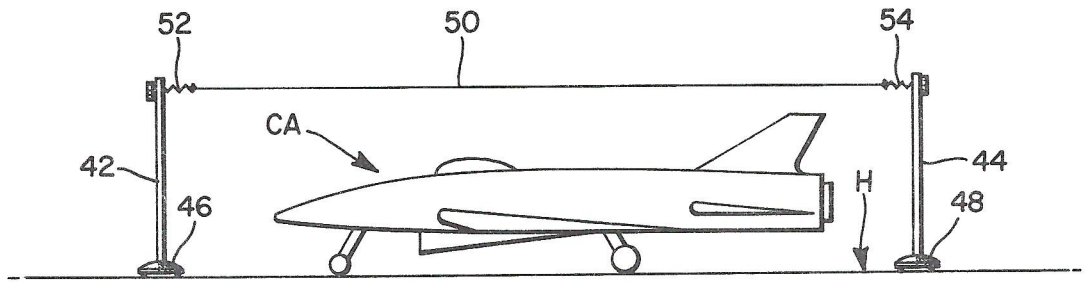

FIGURE II

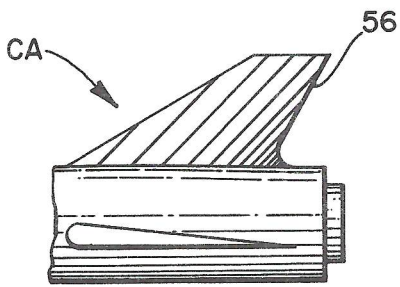

FIGURE 13

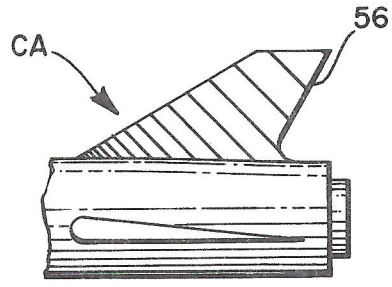

FIGURE 14

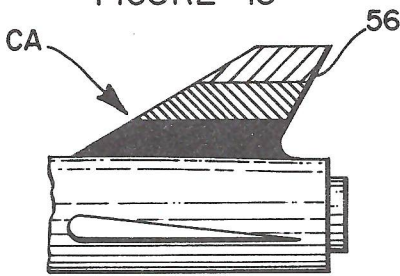

FIGURE 15

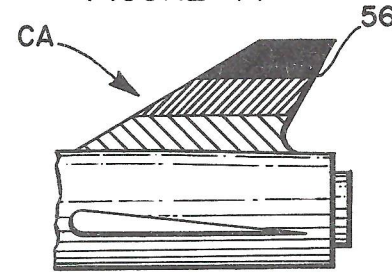

FIGURE 16

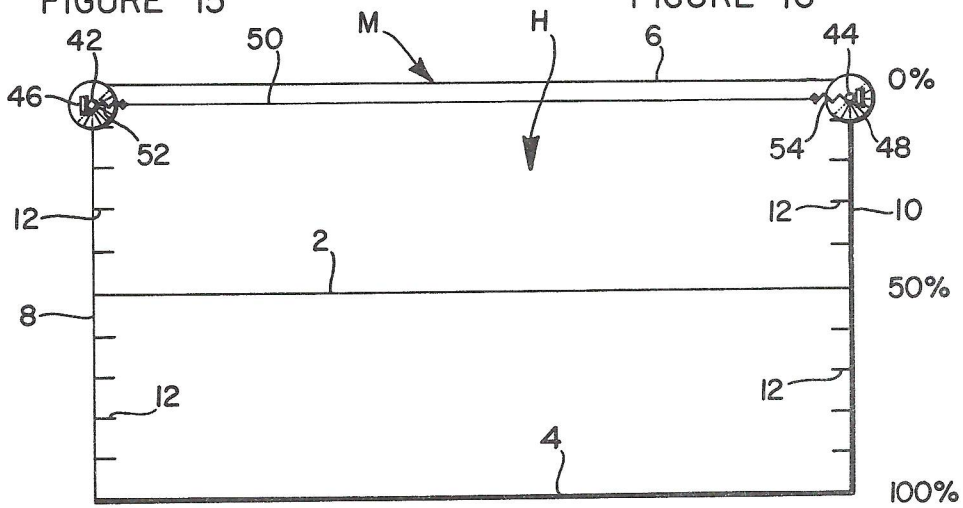

FIGURE 12

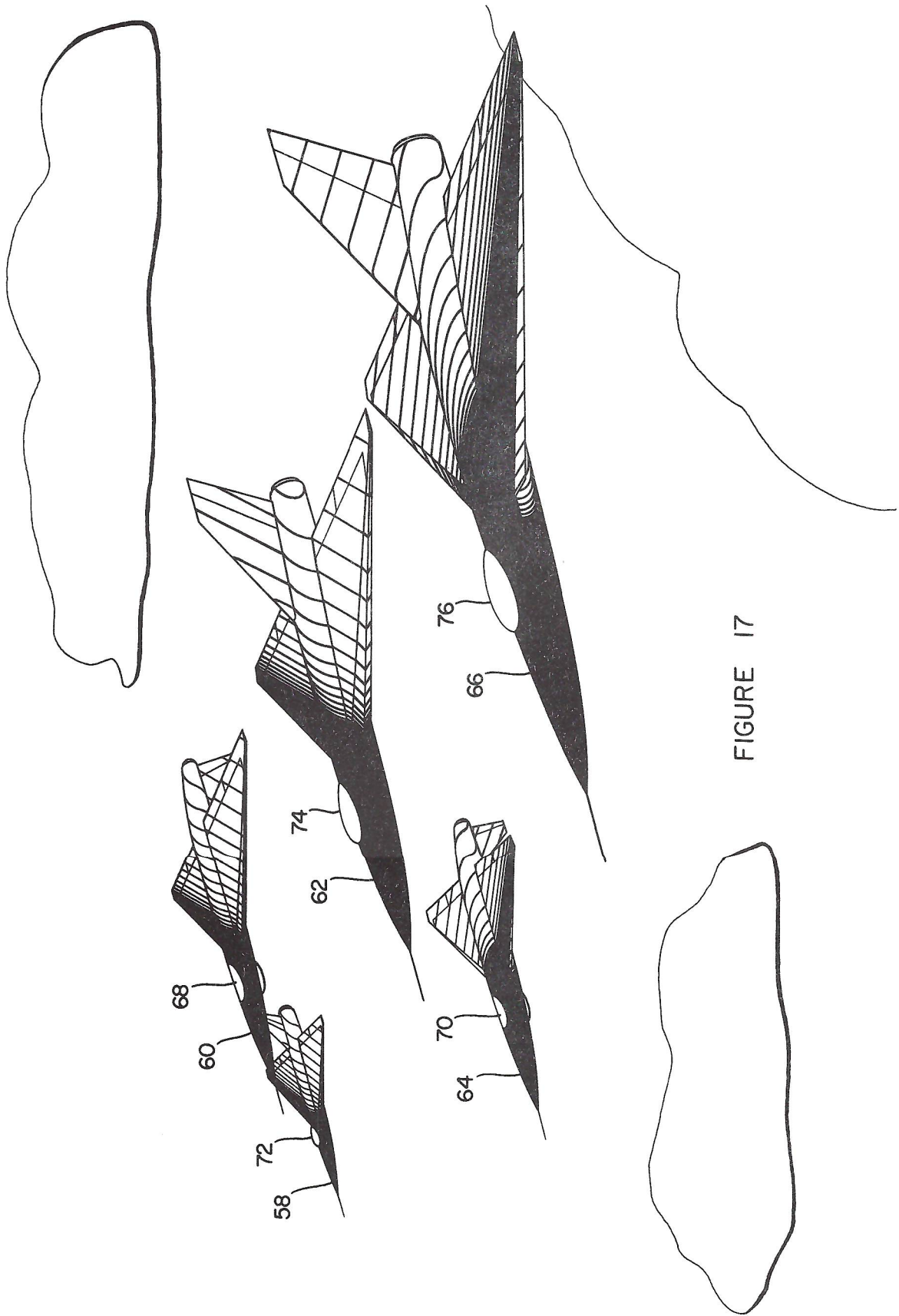

FIGURE 17