

- [54] CAMOUFLAGED AIRCRAFT, SURFACE VESSEL OR VEHICLE OR THE LIKE
- [76] Inventor: Carlisle Keith Ferris, 50 Moraine Rd., Morris Plains, N.J. 07950
- [21] Appl. No.: 668,983
- [22] Filed: Mar. 22, 1976
- [51] Int. Cl.² B64D 7/00
- [52] U.S. Cl. 244/1 R; 89/36 R; 427/280; 428/195; 428/919
- [58] Field of Search 244/1 R; 114/15; 89/36 R; 428/919, 195; 427/261, 280

[56] References Cited

U.S. PATENT DOCUMENTS

| | | | |
|-----------|--------|---------|---------|
| 1,305,296 | 6/1919 | Mackay | 114/15 |
| 2,190,691 | 2/1940 | Barclay | 114/15 |
| 2,292,848 | 8/1942 | Robson | 114/15 |
| 3,967,026 | 6/1976 | Daiblom | 428/195 |

FOREIGN PATENT DOCUMENTS

| | | | |
|---------|--------|---------|--------|
| 615,111 | 2/1933 | Germany | 114/15 |
|---------|--------|---------|--------|

OTHER PUBLICATIONS

The Encyclopedia Americana, "Concealing Color-

ation," pp. 325-326a, Countershading and Disruptive Markings, p. 326b, 1964.

Primary Examiner—Stephen C. Bentley
 Attorney, Agent, or Firm—Shlesinger, Arkwright, Garvey & Dinsmore

[57] ABSTRACT

A camouflaged aircraft, surface vessel, vehicle or the like comprising an aircraft having upper and lower surfaces and having a plurality of visually contrasting surface coatings thereon, the coatings having lines of demarcation therebetween the surface coatings comprising one light and one dark coating, the dark coating being on a major portion of the upper surface of said aircraft, the light coating being on a major portion of the lower surface of the aircraft, substantially all of the lines of demarcation of the coatings when viewed from the side of the aircraft generally paralleling the longitudinal axis of the aircraft, and substantially all of the lines of demarcation of the coatings when viewed from above the aircraft being generally diagonal with respect to the longitudinal axis of the aircraft and substantially all of the lines of demarcation running in substantially the same direction.

45 Claims, 16 Drawing Figures

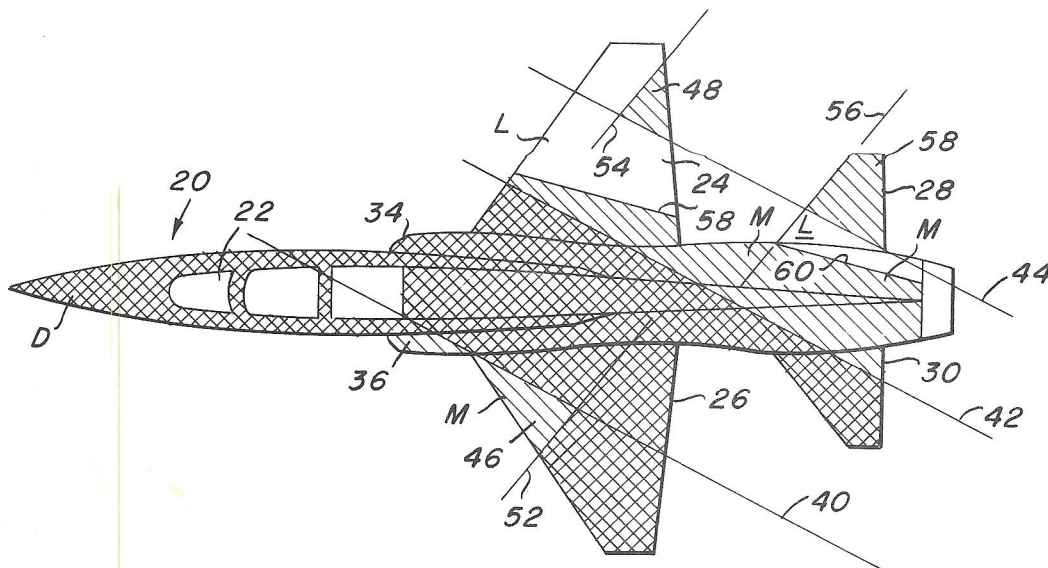

Fig. 1

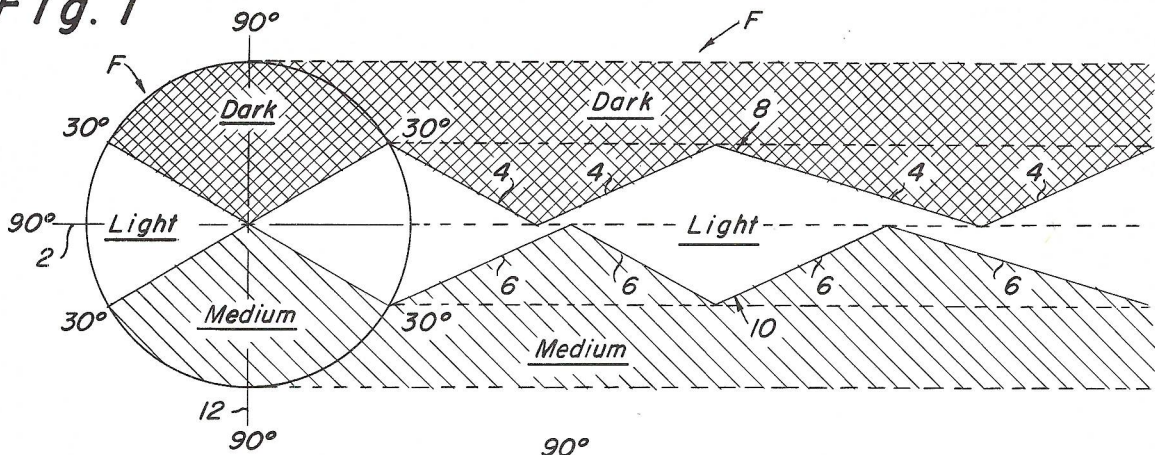

Fig. 2

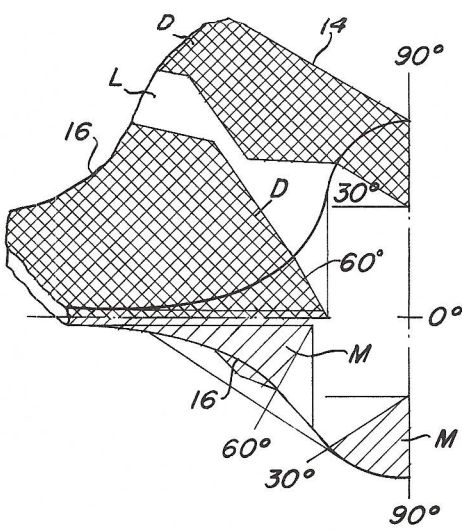
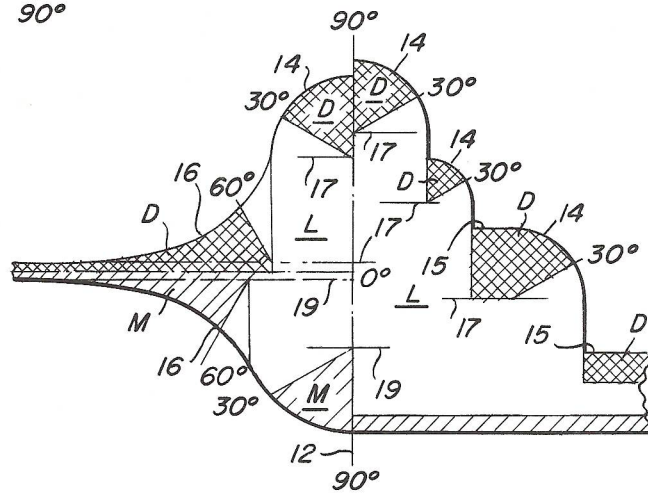

Fig. 3

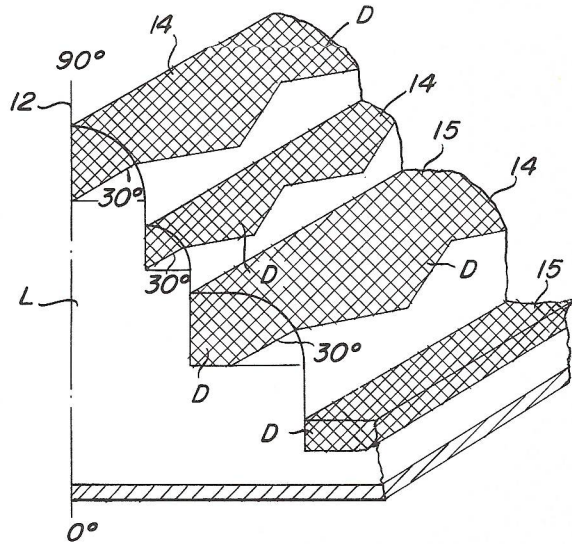

Fig. 4

Fig. 5

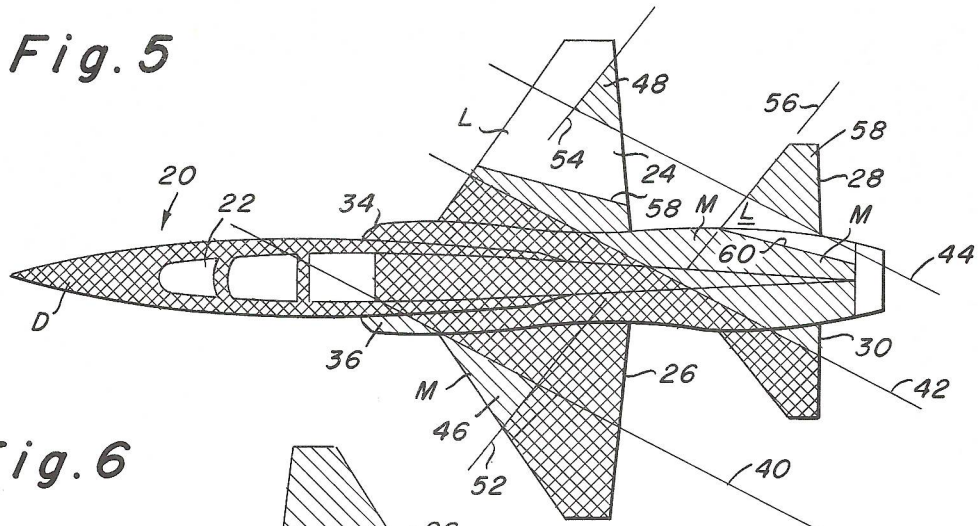

Fig. 6

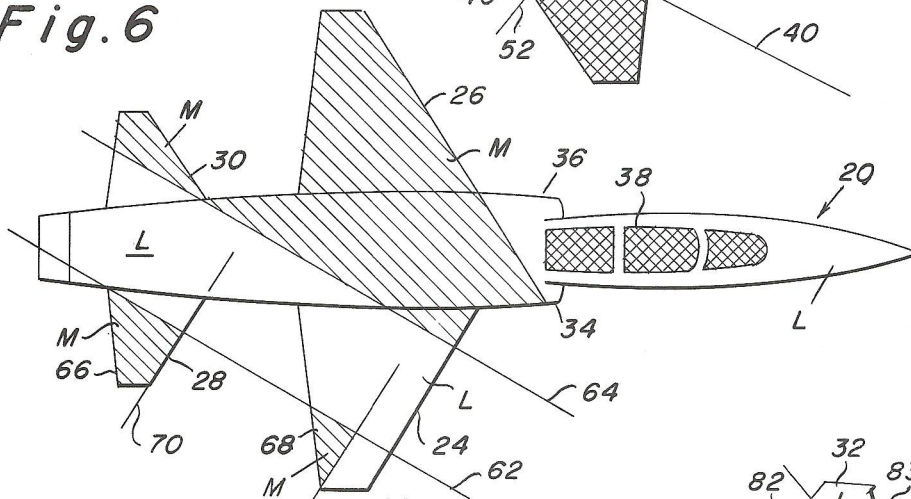

Fig. 7

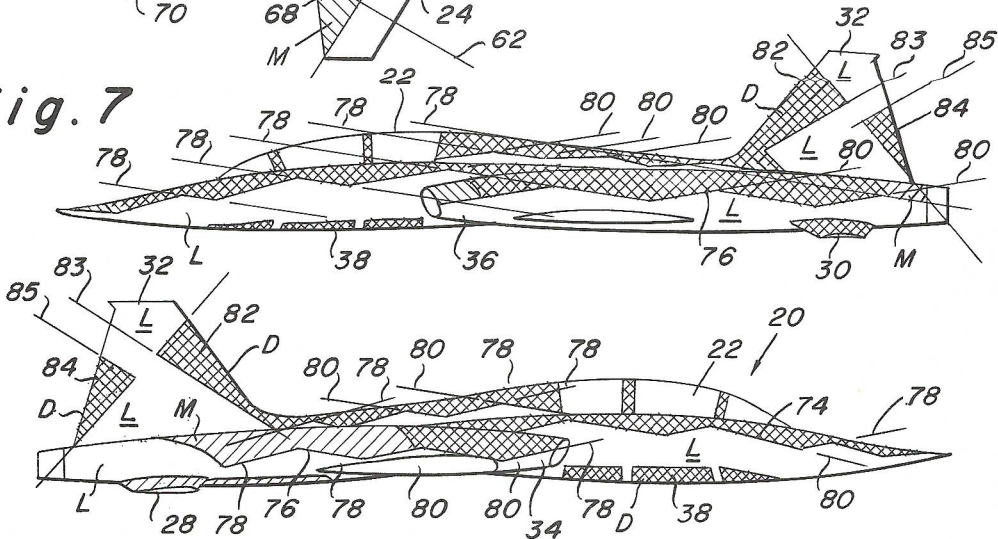

Fig. 8

Fig. 9

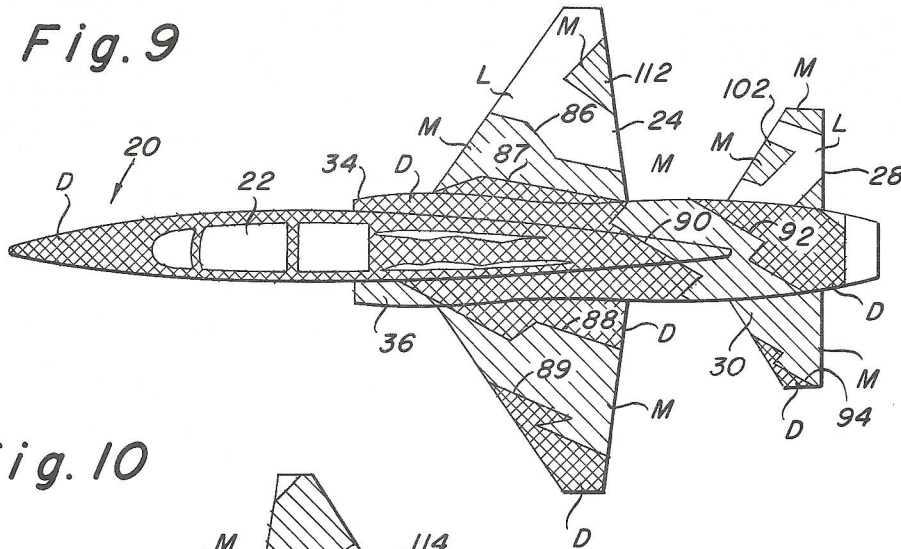

Fig. 10

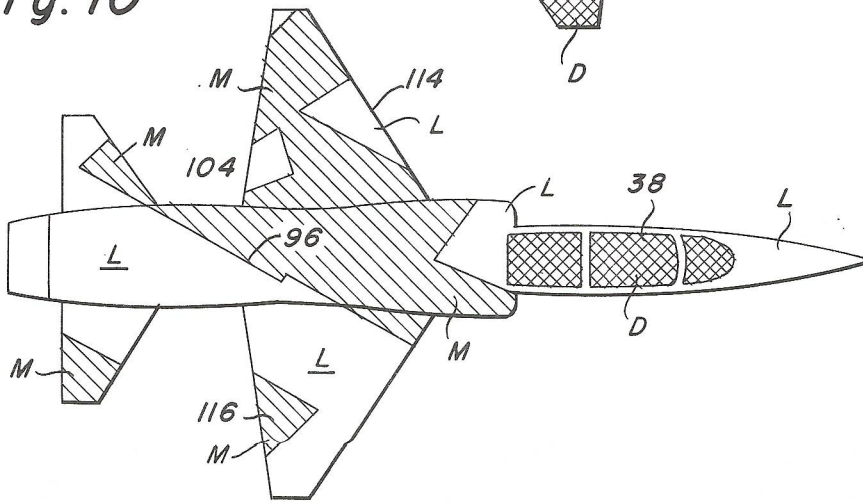

Fig. 11

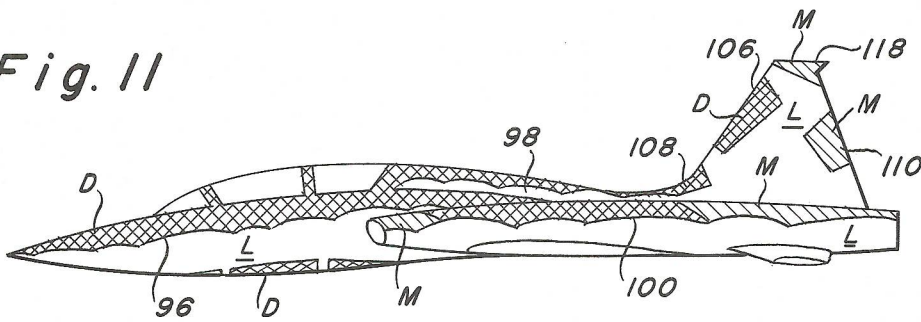

Fig. 12

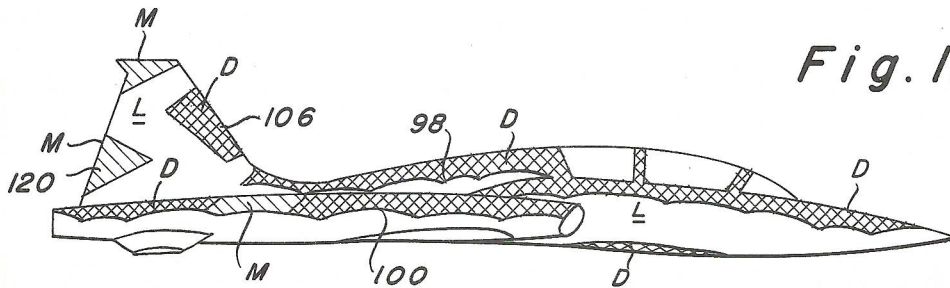

Fig. 13

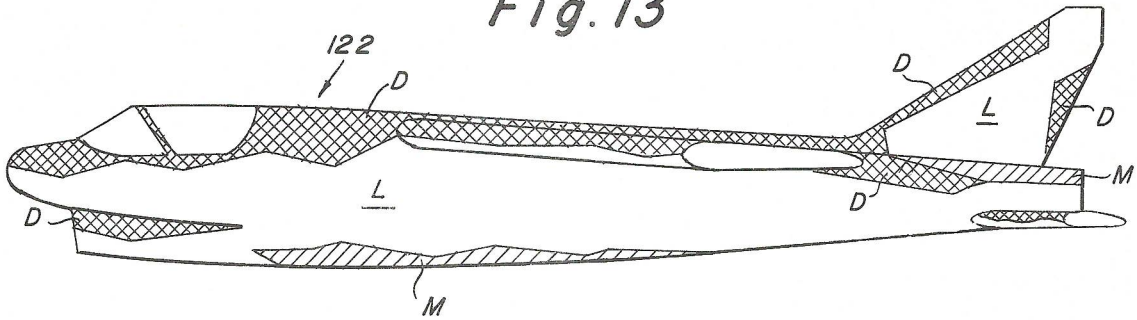

Fig. 14

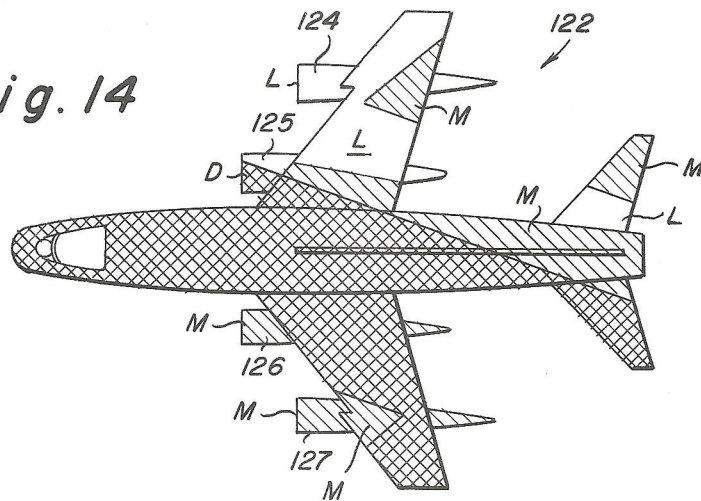

Fig. 15

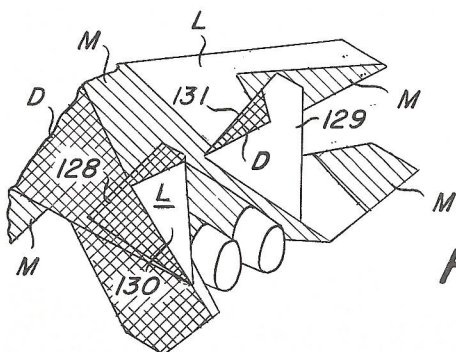
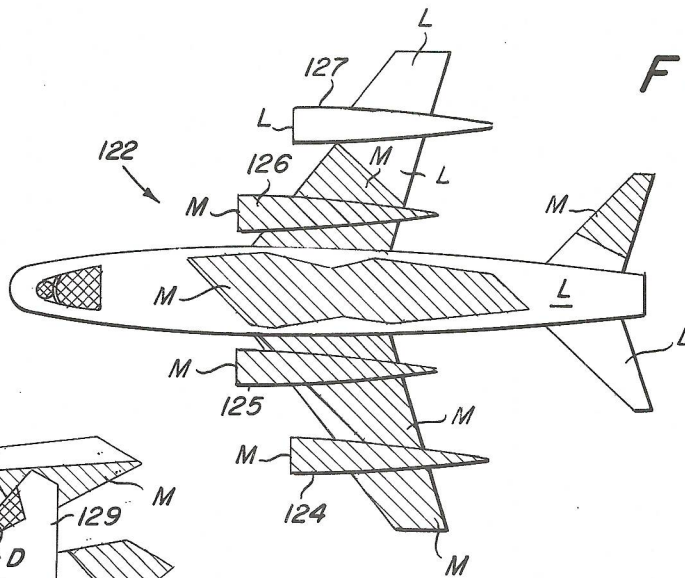

Fig. 16